

Published in May 2010 by the Workplace Safety and Health Council in collaboration with the Ministry of Manpower.

All rights reserved. This publication may not be reproduced or transmitted in any form or by any means, in whole or in part, without prior written permission. The information provided in this publication is accurate as at time of printing. All cases shared in this publication are meant for learning purposes only. The learning points for each case are not exhaustive and should not be taken to encapsulate all the responsibilities and obligations of the user of this publication under the law. The Workplace Safety and Health Council does not accept any liability or responsibility to any party for losses or damage arising from following this publication.

This publication is available on the Workplace Safety and Health Council website: [www.wshc.gov.sg](http://www.wshc.gov.sg)  
Email: [contact@wshc.gov.sg](mailto:contact@wshc.gov.sg)

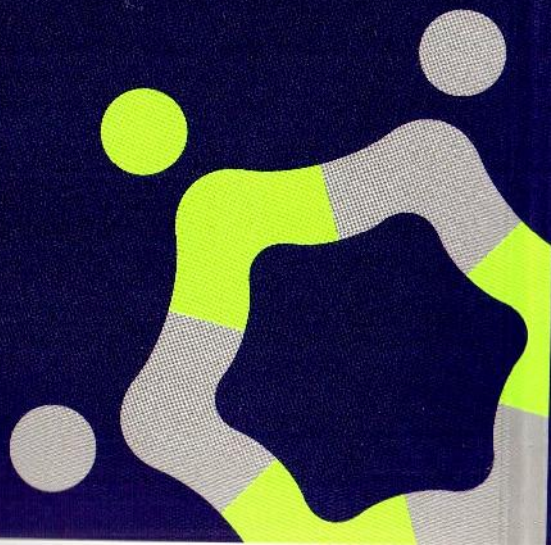

# Workplace Safety and Health Guidelines

## Safe Loading on Vehicles



# Contents

<b>1.</b>	<b>Preface</b>	<b>3</b>
<b>2.</b>	<b>Introduction</b>	<b>4</b>
2.1	Scope	4
2.2	Terms and Definitions	4
<b>3.</b>	<b>General Requirements</b>	<b>6</b>
3.1	Basic Principles	6
3.2	Vehicles for Different Loads	6
3.3	Headboards	8
3.4	Stanchions	9
3.5	Anchorage Points	10
3.6	Load Securing Equipment	11
3.7	Lashing/ Tie-down	12
3.8	Stacking/ Placement of Cargoes	13
<b>4.</b>	<b>Hazards of Unsafe Loading</b>	<b>15</b>
<b>5.</b>	<b>Roles and Responsibilities</b>	<b>16</b>
<b>6.</b>	<b>Risk Assessment</b>	<b>17</b>
<b>7.</b>	<b>Safe Loading for Different Cargo Types</b>	<b>18</b>
7.1	General Load	18
7.1.1	Drums	18
7.1.2	Boxes	19
7.1.3	Sacks/ Bags	19
7.1.4	Bales/ Bundled	21
7.1.5	Tyres	22
7.1.6	Break Bulk/ Loose Cargo	22
7.2	Palletised Load	23
7.2.1	Empty Pallet	23
7.2.2	Palletised Cargo	24
7.3	Metals/ Steel Load	25
7.3.1	Steel Plates/ Structural Steel (bundled/ loose)	25
7.3.2	Pipes (bundled/ loose)	28
7.3.3	Ingot/ Bars	30
7.3.4	Coils	31
7.3.4.1	Metal Sheet Coil (on trailers)	31
7.3.4.2	Metal Sheet Coil (palletised)	33
7.3.4.3	Metal Coil (on wedge bed)	34
7.3.4.4	Steel Wire Coil	34
7.3.4.5	Cable Drum	35

7.4	Timber Load	36
7.5	Heavy Machines/ Equipment	38
7.6	Containers	39
7.7	Precast	39
7.8	Others	40
7.8.1	Jumbo Bags	40
7.8.2	Scrap Metal	41
7.8.3	Car Transporters	42
7.8.4	Tote Bins	43
7.8.5	Metal Panels	43
7.8.6	Other Cargo Types	44
<b>8.</b>	<b>Dos and Don'ts for Loading on Vehicles</b>	<b>46</b>
<b>9.</b>	<b>Acknowledgements</b>	<b>52</b>
<b>10.</b>	<b>Annex</b>	<b>53</b>
<b>11.</b>	<b>References</b>	<b>54</b>

# 1. Preface

This guideline is jointly developed by the Container Depot Association (Singapore), Singapore Logistics Association, Singapore Transport Association, PSA Corporation Ltd and Jurong Port Pte Ltd, with support from Ministry of Manpower (MOM) and Workplace Safety and Health (WSH) Council.

This guideline contains general safety pointers for transport operators on loading safely on vehicles. It is intended to be simple and easy to understand by users such as hauliers and drivers. However, it is not intended to be exhaustive or to be relied on solely as a substitute reference to the Motor Vehicles (construction and use) Rules 1974 or the Code of Practice (CP30) for Safe Loading on Vehicles. Users are advised to use this guideline in conjunction with the other relevant materials or references where appropriate.

This guideline is produced for education and informational purposes by the Safe Loading Committee and serves as a pointer for good practices.

The learning points and information are not exhaustive and should not be taken to encapsulate all the responsibilities and obligations of the reader.

All opinions, suggestions, recommendations, and conclusions in this guideline are those of the Committee and not necessarily those of any participating person or organisation.

## 2. Introduction

### 2.1 Scope

This guideline provides information and guidance to transport operators, drivers, loading staff and key stakeholders who are involved in loading on vehicles. It aims to raise the awareness of and inculcate the basic safety principles that must be followed, and to conduct proper risk assessment for the types of cargo transported.

Information provided in this guideline includes good practices for safe loading on vehicles, and the different acceptable placement and securing/ restraining methods. The guideline also covers other safety considerations such as the consequences of unsafe loading and risk assessments on restraining some cargo types.

This guideline is not intended to be prescriptive in nature; it provides reasonable practicable guidance to ensure loading on vehicles can be done safely to the persons involved in the work and the general public.

### 2.2 Terms and Definitions

Term	Definition
<b>Anchorage Point</b>	Part of the structure, fitting or attachment on a vehicle to which a tie-down is attached. It is designed to withhold the load restraints to the main chassis frame of the vehicle.
<b>Attached</b>	To prevent load from shifting by using lashing method.
<b>Bale</b>	A large package of raw or finished material often wrapped and tightly bound with twine or wire.
<b>Blocked</b>	To restrain load from shifting by using the blocking method.
<b>Blocking</b>	A structure, device or another substantial article placed against or around an article of cargo to prevent its horizontal movement.
<b>Contained</b>	To prevent load from falling off the vehicles without use of any securing devices.
<b>Container</b>	A large reusable receptacle, designed for efficient handling of cargo, that can accommodate smaller cartons or cases and any types of cargoes in a single shipment. Containers should be constructed to International Organization for Standardization (ISO) or British Standards (BS).

<b>Dunnage</b>	The loose mask material or wooden block, used to hold up the load of the cargo from the bottom of the vehicle during transportation.
<b>Direct Restraint</b>	A load is prevented from being shifted by containing, blocking or attaching it to the vehicle.
<b>Friction Mat</b>	A device placed between the deck of a vehicle and articles of cargo, or between articles of cargo, to provide greater friction between surfaces.
<b>Hazard</b>	It is anything with the potential to cause bodily injury, and includes any physical, chemical, biological, mechanical, electrical or ergonomic hazard.
<b>Headboard</b>	A vertically constructed structure that is not part of the cabin structure. It is specially designed to withstand a certain amount of horizontal force.
<b>Lashing</b>	Material used for securing load to prevent it from moving or falling off the vehicle.
<b>Load</b>	The overall force to which a structure is subjected in supporting a weight or mass or in resisting externally applied forces.
<b>Pallet</b>	A portable platform used for storing or moving cargo or freight.
<b>Payload</b>	It is the load difference between the maximum laden weight and the unladen weight of the vehicle.
<b>Restraint Devices</b>	These include ropes, steel wire ropes, belts, chains and specially designed webbing strappings which should only be used for applications approved by their respective manufacturers.
<b>Risk</b>	It is the likelihood of a hazard causing a specific bodily injury to any person.
<b>Risk Assessment</b>	It is the process of evaluating the probability and consequences of injury or illness arising from exposure to an identified hazard, and determining the appropriate measures for risk control.
<b>Stanchions</b>	Metal bar and/or steel rod, placed at the edge of the trailers to serve as fence to prevent stacked cargoes from falling off the vehicle.
<b>Tie-Down</b>	To fasten the cargo with chains, ropes, belts or straps to a vehicle's or trailer's anchorage point(s).

## 3. General Requirements

### 3.1 Basic Principles

- The load in a vehicle must not endanger any person in or on the vehicle or on the road at all times.
- The load on a vehicle must be properly secured so that it would not endanger any person if it or part of it moves.
- Cargo must be contained or secured so it does not leak, spill, blow, fall from, fall through, become dislodged, swing or shift and make the vehicle unstable.

### 3.2 Vehicles for Different Loads

- The vehicle must be strong enough to withstand the pressure when it is being used to transport cargo.
- Appropriate type of vehicle should be used according to the type of loads it is transporting. Alternatively, the vehicle must be made suitable by using fittings, fixtures, dunnage or other means.
- Vehicle must not exceed the maximum laden weight when carrying the load.
- The vehicle must be designed for the load, that is, with anchor points, platform, and headboard.
- Common vehicles used for transporting cargo are container trailers, lorries, low loaders/low bed trailers, pick-ups, car transporters and vans.

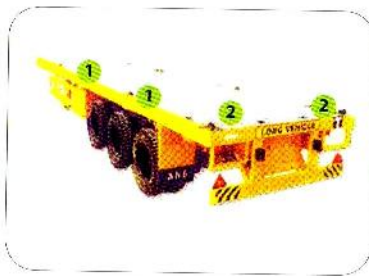

Empty flatbed trailer

1. Anchor Points
2. Twistlocks

Figure 1: Flatbed cargo trailers for containers and break bulk cargo

- Flatbed cargo trailers fixed with twistlocks are used to transport containers and break bulk cargo.



Empty low bed trailer



1. Excavator



2. Crane boom's parts



3. Engineering plant

Figure 2: Low bed trailers (low loaders) for out-of-gauge containers and heavy cargo

- Low bed trailers are used for transporting out-of-gauge (OOG) containers and oversized/heavy cargo such as machinery, excavators, crawler cranes, construction equipment and other heavy lifts.
- They are also used for transporting loads on roads with weight and height restrictions.
- Some low bed trailers allow equipment to be driven onto its platform.
- Some lorries are fitted with panels to protect the cargo from rain and sun.
- They are used for transporting palletised cargo and loose cargo packed in cartons, cases, bags, bales, bundles, drums, etc.
- Lorries come in different sizes and have different carrying capacities. Their capacities are indicated at its side. The weight of the load should not exceed the indicated maximum laden weight.
- Pick-up trucks (also known as mini trucks) are smaller version of lorries.
- They are used for transporting ship stores to the vessels or engineering parts to workshops or stores.
- The loads must also be safely secured in these vehicles.



Lorry with sideboard extension

1. Rear board
2. Sideboard Extension
3. Sideboard
4. Headboard

Figure 3: Lorry for transporting palletised cargo and loose cargo



Figure 4: Mini or pick-up trucks for ship stores, engineering parts or light cargo

### For Lightweight Cargo and Store Items

- They are used for carrying lightweight goods or stores for the vessels and workshops.



Figure 5: Van for light weight cargo and store items

### 3.3 Headboards

- Headboards must be strong enough to prevent loads such as metal bars, beams, pipes, girders, sheet metal, and so on, from penetrating the cab of the vehicle if the securing devices fail.
- The top load must not be stacked above the headboard.

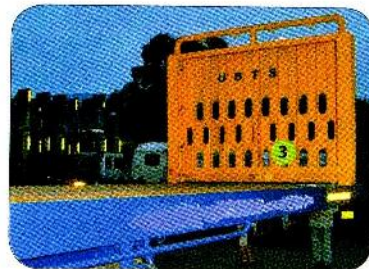

1. Headboard behind cabin
2. Headboard on lorry

3. Headboard fitted on trailer

Figure 6: Various designs of headboards

### 3.4 Stanchions

- Whenever stanchions are used to provide lateral restraint of the loads, they must be extended to the height of the loads.
- Stanchions used must be strong enough to resist any outward movement of the loads.
- There should be sufficient number of stanchions installed on the vehicle to restrain the loads. For example, two stanchions can be installed on each side of a 20-footer trailer or at least four on each side of a 40-footer trailer.

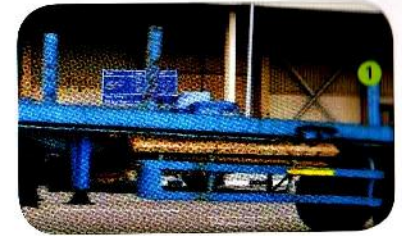

1. Stanchion

Figure 7: Example of stanchion

### 3.5 Anchorage Points

- Vehicles are required to provide adequate and appropriate anchor points to suit the payload capacity and the type and nature of load to be carried.
- Appropriate securing devices must be used to secure the loads safely.

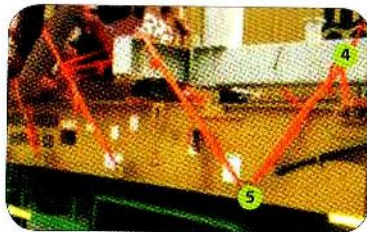
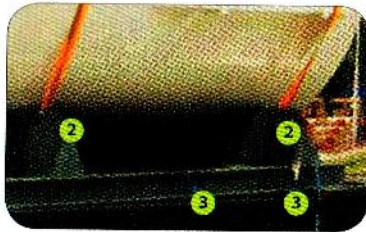
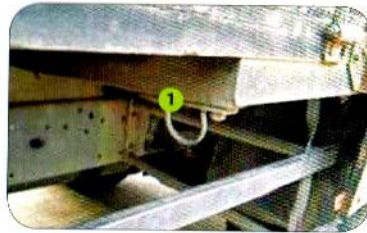
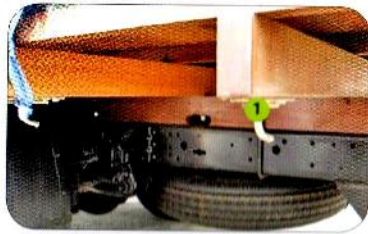

Uncontainerised cargo (UC) is secured to a platform. The platform is then secured to the anchor points of the trailer.

1. Anchor point
2. Cargo is secured to the anchor points on a platform.
3. The load is then secured to the anchor points on the trailer.

Anchor points on a container with webbing belts.

4. Webbing belt with seal buckle
5. Anchor point

Figure 8: Examples of anchor points

### 3.6 Load Securing Equipment

Depending on the type of loads, different securing equipments such as chains, ropes, webs, strappings, and so on, should be considered. They should be used for the load type according to safe work procedures.



Chain sling hook

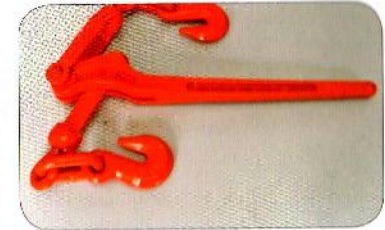

Ratchet load binder

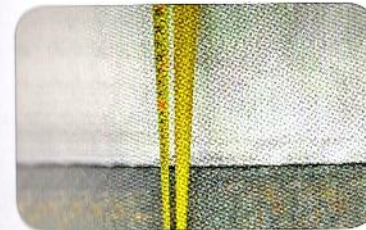

Steel bar/ rod



Alloy steel chain with one end grab hook



Lashing belt and rope



Turn buckle



Turn buckle

Figure 9: Types of load securing equipment

### 3.7 Lashing / Tie-down

- Adequate and proper lashing device must be used to secure the loads.
- Lashing must be checked and retightened regularly.
- Check and ensure that the loads are stable before lashing or loosening the straps.
- The load should be restrained in such a way that no part of it is free to move in any direction independently from the rest.
- The load restraint equipment and vehicle body must be strong enough for the type of load carried.

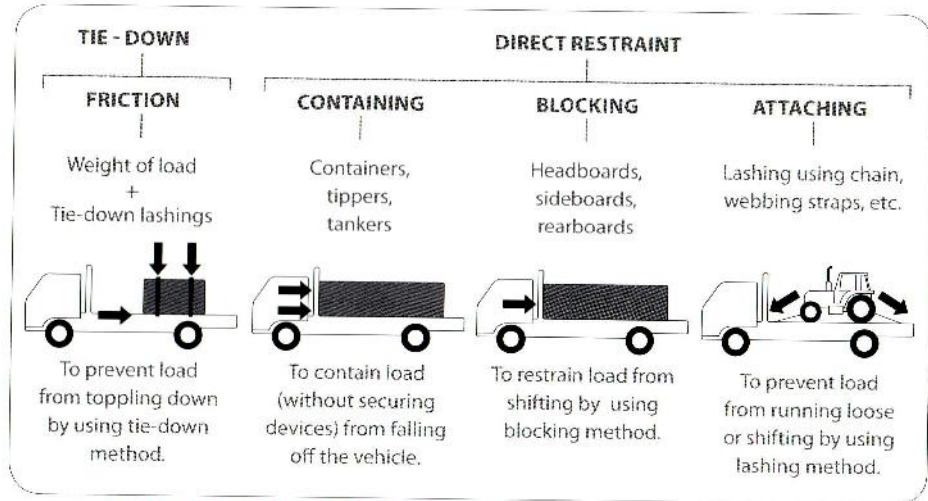

Figure 10: Illustration of tie-down and direct restraint

The **tie-down method** is the most common form of load restraint and involves the use of lashings. This method prevents the load from sliding in any direction. The lashings are used to tie the load tightly to the vehicle to prevent the load from moving upwards.

In the **direct restraint method**, a load can be directly restrained by containing, blocking or attaching without any assistance from friction. **Contained** loads can be directly restrained without any securing devices. These include liquids in tanks, bulk solids in tanks and general cargo in containers. **Blocked** load is directly restrained by blocking against vehicle structures or other items of load or packing them in contact with the structures. These structures include headboards, sideboards and rear boards. **Attached** loads are directly restrained by lashings that provide all the necessary restraint.

As a general guide the minimum number of tie-downs are:

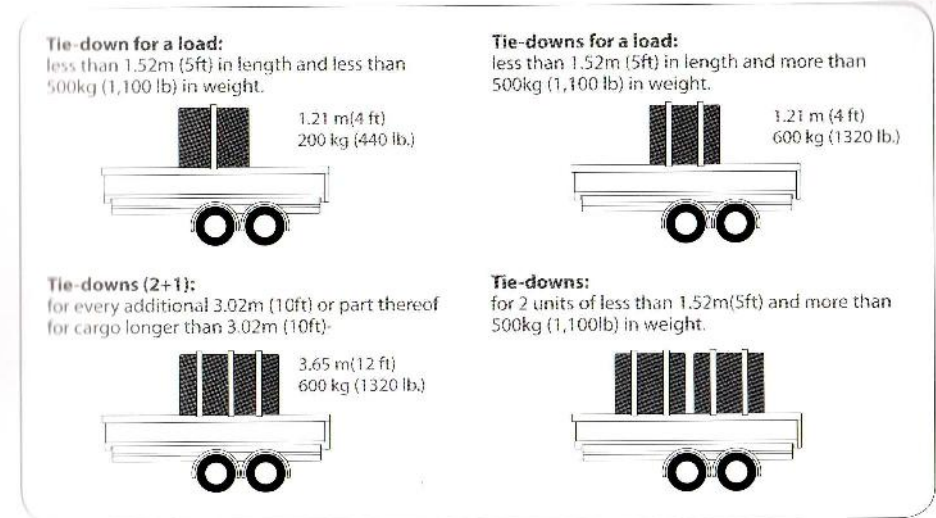

Figure 11: Minimum number of tie-downs

### 3.8 Stacking / Placement of Cargoes

- Loads must be stacked in a manner that is stable without lashing.
- Cargoes must be placed in such a way that their weight is disposed uniformly over the vehicles' platform. This helps to maintain the lateral and longitudinal stability of the vehicles.
- The position of the centre of gravity of the cargoes is critical. It should be kept as low and as forward as possible at all times to prevent the vehicles from overturning.
- All loads must be restrained or secured to prevent unacceptable movement during all expected conditions of operation.

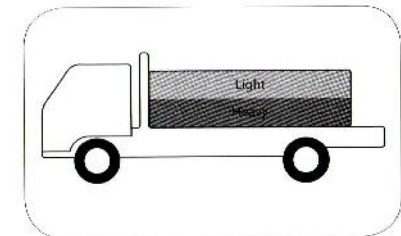
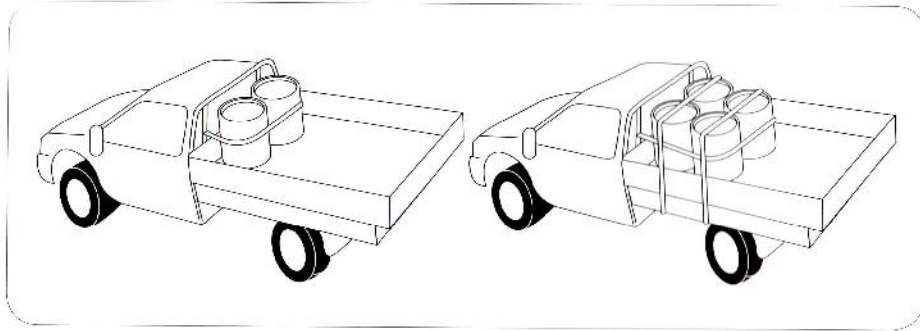

Figure 12: Light cargo should be placed on top of heavy ones





Ways to strap two and four units of drums.

Figure 13: Ways to strap drum cargoes



Figure 14: Placement of cargoes on lorries and trailers with tie-down to secure the cargo from movement

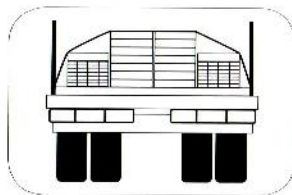

Figure 15: Load position—weight distributed evenly across the trailer which would improve vehicle stability

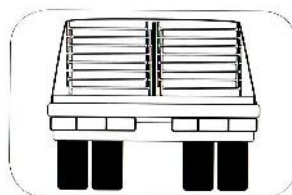

Figure 16: Double stacked loads must be locked together with no gaps "over the top" chains



Figure 17: Use crates or steel boxes to contain and block items against the headboard of the vehicle cabin

## 4. Hazards of Unsafe Loading

See Figures 19-21 for examples of incidents involving unsafe loading.



Figure 18: Tin ingots toppled from vehicle due to sudden braking and unsafe stacking



Figure 19: Pipes not properly secured and truck did not have a headboard



Figure 20: Metal bars and pipes not properly stacked and secured on trailer, hence they slid off when the trailer made a sharp turn



Figure 21: I-beam not properly lashed and secured on trailer and trailer did not have headboard

## 5. Roles and Responsibilities

### Management should ensure that:

- sufficient resources essential to the operation are made available;
- competent persons are appointed to carry out the task; and
- risk assessment is being conducted and approved for each of the operation.

### Person-in-charge of operation planning should:

- give instructions to driver for each operation; and
- prepare risk assessment for each operation.

### Driver should:

- check that the vehicle and all ancillary equipment are fit for the operation and that they meet all requirements specified in the instructions given for the operation;
- take the necessary precautions to prevent the vehicle from moving during the loading/unloading process;
- ensure that the cargo is properly loaded onto the vehicle;
- report all loading/discharge problems, unsafe situations or conditions, near misses and incidents as required by company procedures;
- ensure that cargoes are stowed and secured with sufficient lashings in such a way that they cannot shift in any direction; and
- not leave the loading site without checking stowage and securing.

## 6. Risk Assessment

**Risk Assessment** is an integral part of risk management. It is the process of:

- Identifying and analysing safety and health hazards associated with work;
- Assessing the risks involved; and
- Prioritising measures to control the hazards and reduce the risks.

### Management/ operation staff should:

- have adequate knowledge of the risk assessment method; and
- recommend appropriate risk assessment for each operation to be carried out.

### Drivers/ delivery-men should:

- adhere to risk assessment established to reduce any safety and health risks in the workplace.

### Refer to Annex a Sample Risk Assessment Form for General Loads.

The sample provided in this guideline is for user's reference. The company should prepare proper and appropriate risk assessment for each operation to be carried out.

## 7. Safe Loading for Different Cargo Types

### 7.1 General load

#### 7.1.1 Drums

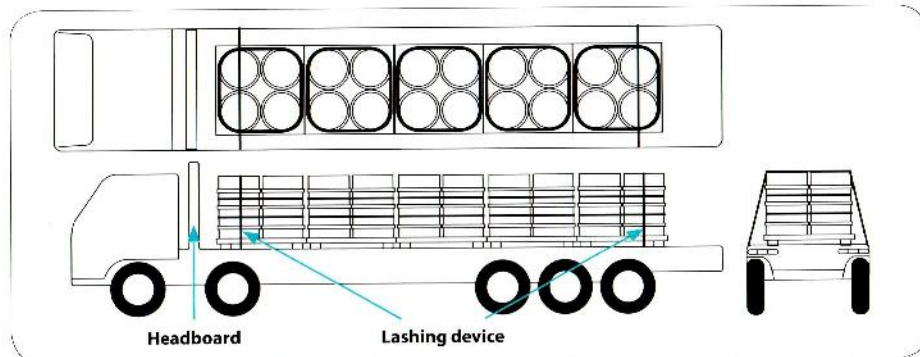

Figure 22: Drums/ cylindrical loads placed vertically on open platform

- The first and last rows must be lashed. Rows towards the rear can also be lashed for added security.
- All drums/ cylindrical loads must be in contact with one another to minimise movement.
- Each lashing line securing the side of the load must pass approximately over the centre height of the loads.
- It is recommended to affix headboard to the vehicle.

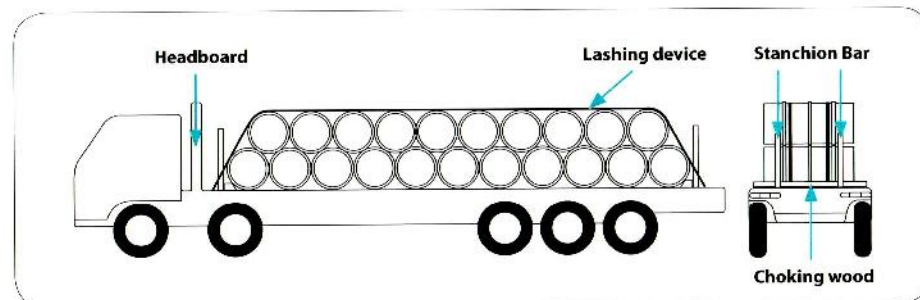

Figure 23: Drums/ cylindrical loads placed horizontally along the axis

- Rolls or cylindrical cargoes should be placed with their axis across the vehicle so that they will tend to row to the front or back.
- If the length is less than twice the diameter of the cylinder, these cargo should be placed to the rear.
- If the length of the cylinder is longer than twice its diameter but less than the width of the vehicle, it must be positioned so as to prevent forward movement. Each row must be in contact with the row in front, and the front and rear rows must be chocked to prevent the cylinders from rolling backward or forward.
- Stanchions used must be able to withstand any outward movement of the cargo.

#### 7.1.2 Boxes

- The loads should be restrained in such a way that no part of it is free to move independently from the rest in any direction.
- All rows must be lashed.
- It is recommended that vehicles are affixed with headboards.



Figure 24: Boxed cargo on open platform

#### 7.1.3 Sacks/ Bags

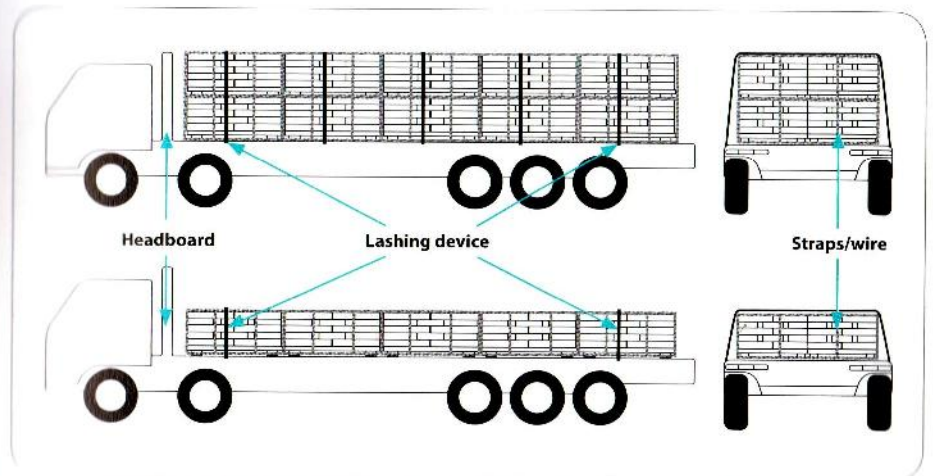

Figure 25: Strapped sacked cargoes on pallets being transported on an open platform

- Sacks should be laid on their sides with alternate layers in opposite direction and no more than two successive layers should be in the same direction.
- When strapping/ wrapping sacked cargoes on pallet, the straps/ wrap/ wires must be able to hold the sacks onto the pallet as a whole.

- Straps/ wires of strapped sacked cargoes on pallet should be checked for damage before loading.
- If there is one layer of strapped sacked cargoes on pallet, lashing is required for the first and last rows. Lashing more rows would be recommended as that would ensure that the cargoes are more secured.
- If there are two layers of strapped sacked cargoes on pallet, each layer must be secured by a lashing device.



Figure 26: One layer of strapped sacks on pallet

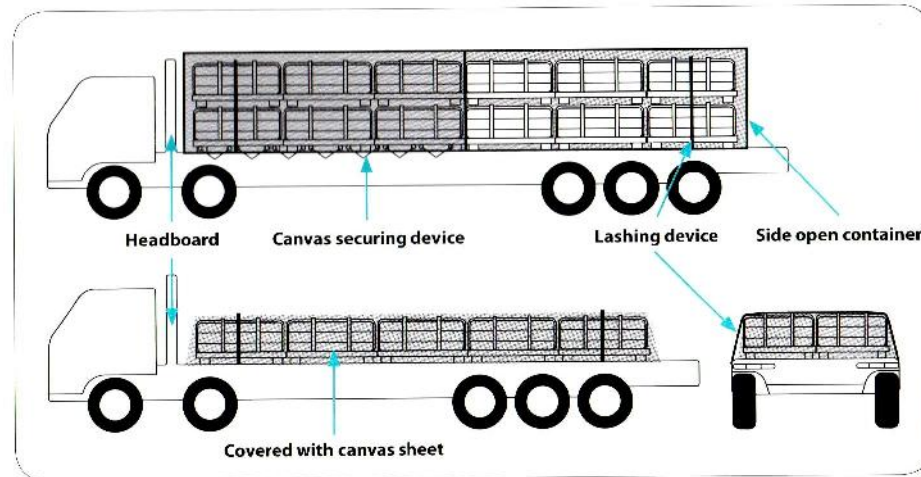

Figure 27: Sacked cargoes onto pallets transported by side open containers

- If the pallets of cargoes are to be transported by side open container with side canvas, two layers can be stacked without lashing every row, but the first and last rows must be secured with lashing devices.
- During transportation, the side canvas must be fully covered and secured.
- If sacks on pallet are not secured as a whole, only one layer is allowed on the vehicle and it must be covered by canvas sheet.

## 7.1.4 Bales/ Bundled

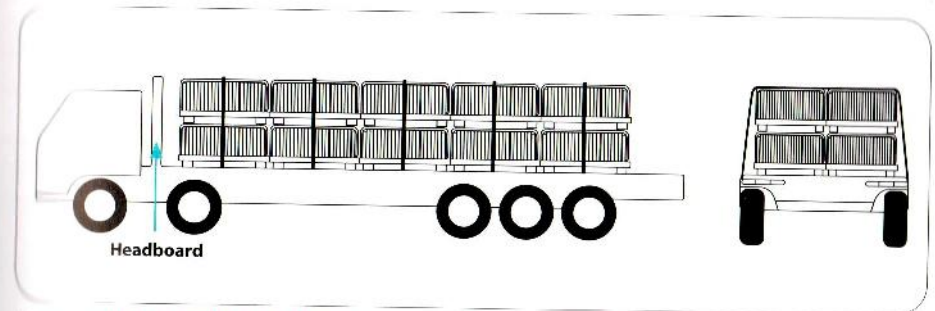

Figure 28: Bales/ bundled loads being transported on open platform

- If the cargoes are stacked in one layer, the cargoes must be lashed at the front and last rows.
- When the cargoes are stacked in two layers, each row must be secured by at least a lashing device.
- It is recommended the vehicle is fitted with a headboard on the platform to prevent the cargoes from falling onto the cabin.



Figure 29: Bundled waste being transported by lorry with headboard



Figure 30: Trailer fixed with headboard for transporting general cargoes e.g., bundled waste

### 7.1.5 Tyres

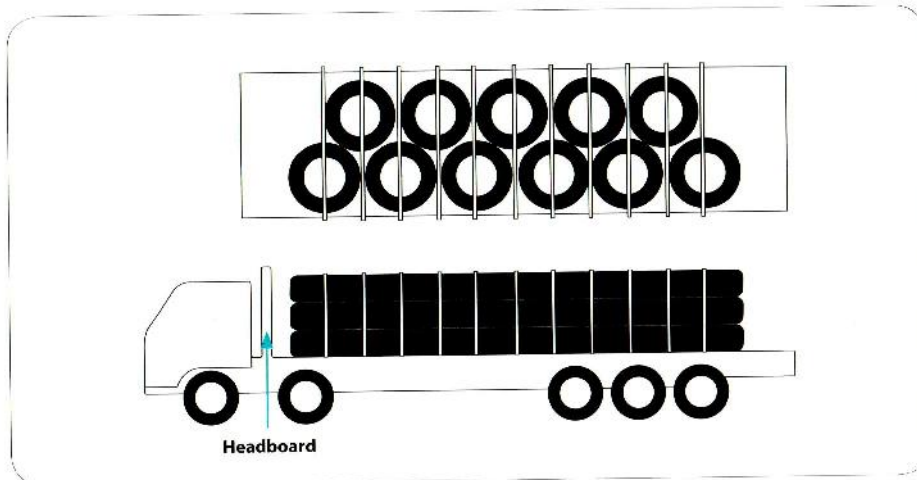

Figure 31: Transporting tyres on open platforms

- Each row of tyres on the platform or lorry must be lashed to prevent them from moving sideways and falling off the vehicle.
- The height of the stacked tyres must not go beyond the height of the driver's cabin.
- Each tie down/ lash system must be attached and secured in a manner to prevent the tyres from loosening from the row.
- Headboards are recommended for vehicles transporting tyres.

### 7.1.6 Break Bulk/ Loose Cargo



Figure 32: Break bulk/ loose cargoes being transported by trailer



Figure 33: Vehicle for break bulk or loose cargoes

- Load should not exceed the height of the headboard or sideboards (including their extension).
- Each pile of the load must be lashed to prevent the cargo from shifting when the vehicle is moving.
- If the cargoes are placed on a trailer/platform, all loads must be in contact with one another or each other. Each pile must be lashed to prevent the cargoes from falling off the trailer or moving towards the driver's cabin.
- It is recommended that headboards are used when the trailers are transporting the break bulk/ loose cargoes.

## 7.2 Palletised Load

### 7.2.1 Empty Pallet

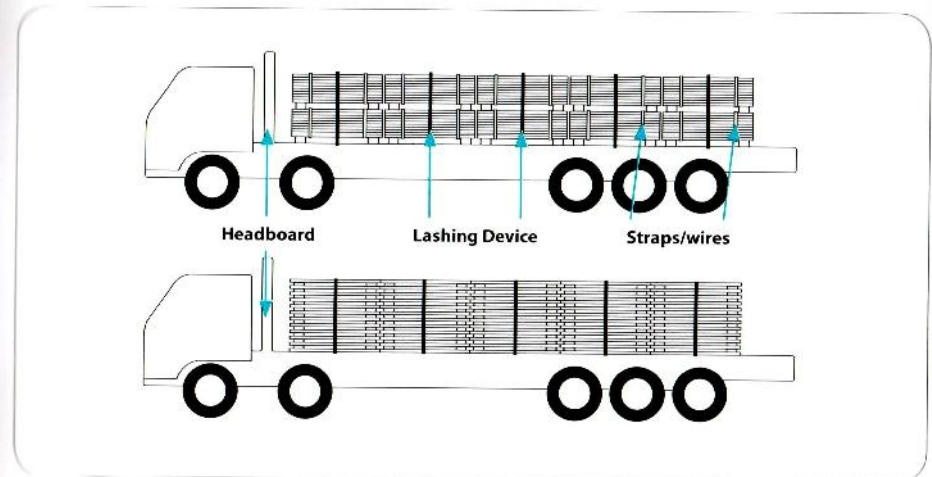

Figure 34: Transportation of empty pallets on trailer

- The load must not be stacked beyond the height of the headboard.
- The loads should be restrained in such a way that no part of it is free to move independently from the rest in any direction.
- It is recommended that headboards are fixed on vehicles to prevent cargoes from moving towards the driver's cabin.

## 7.2.2 Palletised Cargo

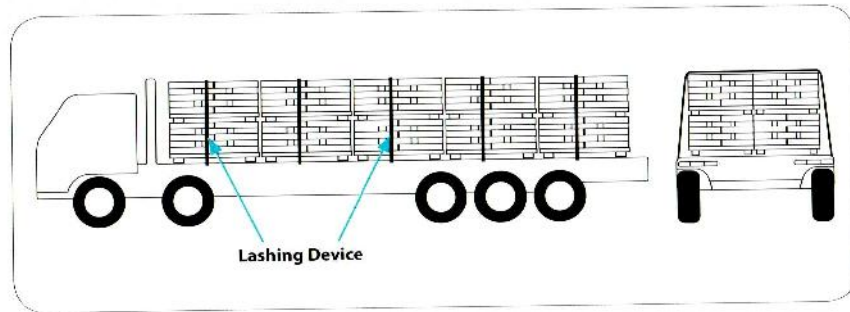
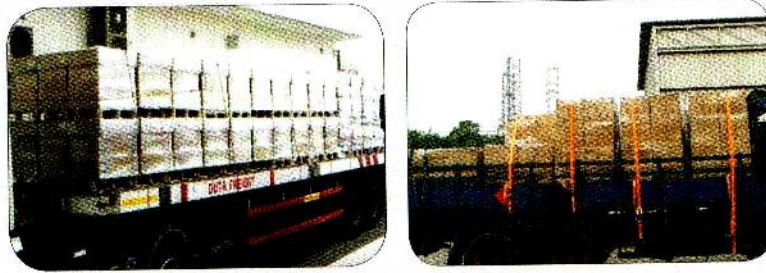

Figure 35: Palletised cargo being transported on lorry with open platform and lorry

- The cargoes stacked on the pallet must be shrink wrapped, stable and secured.
- The pallets used must be in a good condition and are strong enough to withstand the weight of the cargoes being transported.
- Unless the pallets are adequately constrained by the vehicle's body, sideboards and headboards, additional means of restraining the horizontal and vertical movement of the pallets should be provided.
- The layer of cargo on pallets should be stable without any lashing device.
- When pallets are stacked on open platform vehicles, restraining devices must be used to prevent movement of each layer of pallets.
- The front load should be placed further from the cabin.
- Headboards are recommended for vehicles transporting palletised cargo.

## 7.3 Metals/ Steel Load

### 7.3.1 Steel Plates/ Structural Steel (bundled/ loose)

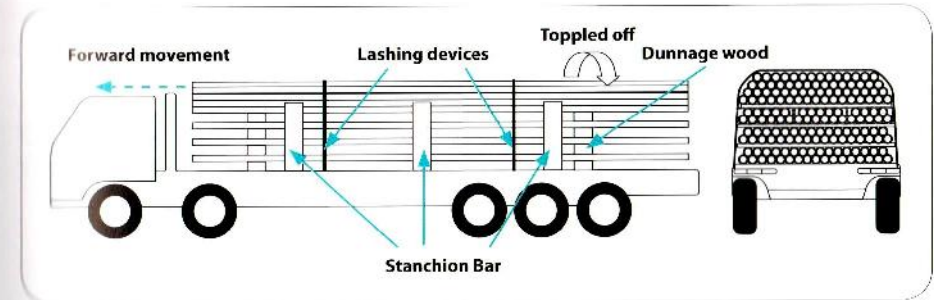

Figure 36: Transportation of metals/ steel loads on open platform

- The load must not be stacked beyond the height of the headboard.
- The load should be restrained in such a way that no part of it is free to move in any direction independently from the rest.
- The stanchions must be extended to the height of the loads and be properly secured.
- A friction mat should be placed between the platform and the cargo to give greater friction to the load to prevent the load from moving forward.
- Install headboards to give better protection to drivers.



Figure 37: Steel plates on open platform trailer

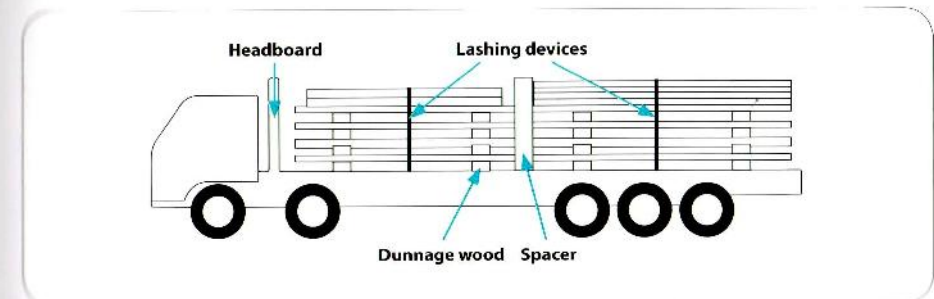

Figure 38: Transporting metals/ steel loads of different sizes

- Smaller plates should be placed on top of larger ones.
- If two or more piles are placed along the deck of the vehicle, the piles must be in contact with one other or a spacer must be put in place to prevent the rearmost piles from sliding into one another.
- Adequate and proper lashing devices (at least two lashing devices per pile) should be used to secure the load to prevent the load from moving or whipping.
- The top pile must not be stacked beyond the height of the headboard.
- Sufficient stanchions should be installed to prevent any outward movement of the load. For example, two stanchions can be installed on each side of a 20-footer trailer or at least four on each side of a 40-footer trailer.
- Install headboards to give better protection to drivers.
- Friction mats can be placed between the cargo and the platform, and inbetween the piles. This will give greater friction to the load, preventing it from moving forward and hitting the cabin.

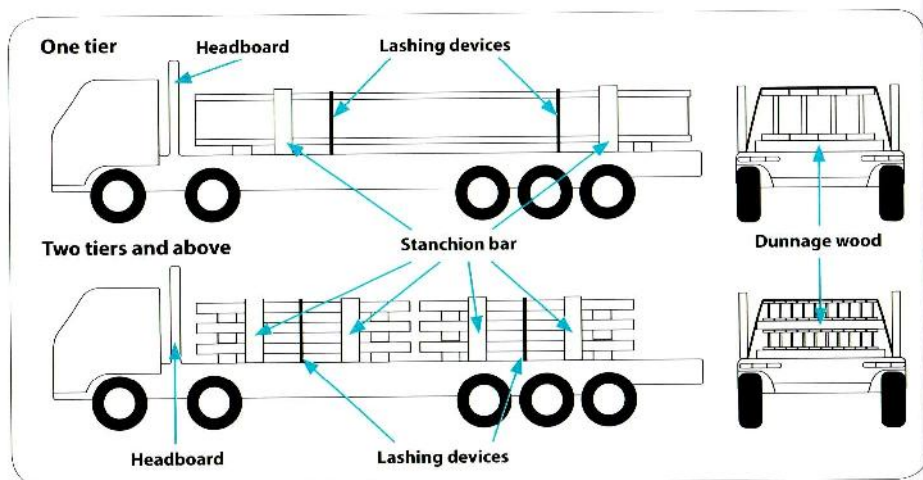

Figure 39: Stacking of structural steel in one layer and above (bundled/ loose)

- The loads must not be stacked beyond the height of the stanchion and the headboard.
- Stanchions provided must be strong enough to withstand any outward movement of the load. For example, two stanchions can be installed on each side of a 20-footer trailer or at least four on each side of a 40-footer trailer.
- The height of the stanchion must be higher than that of the cargo.
- Adequate and proper lashing devices (at least two lashing devices) must be used to secure the loads to prevent any movement.
- Additional lashing devices must be used if there is more than one layer of cargo.
- Loads must be stacked in a manner that is stable without lashing.
- Install headboards to give better protection to drivers.

- Friction mats can be placed between the cargo and the platform, and inbetween the piles. This will give greater friction to the load, preventing it from moving forward and hitting the cabin.

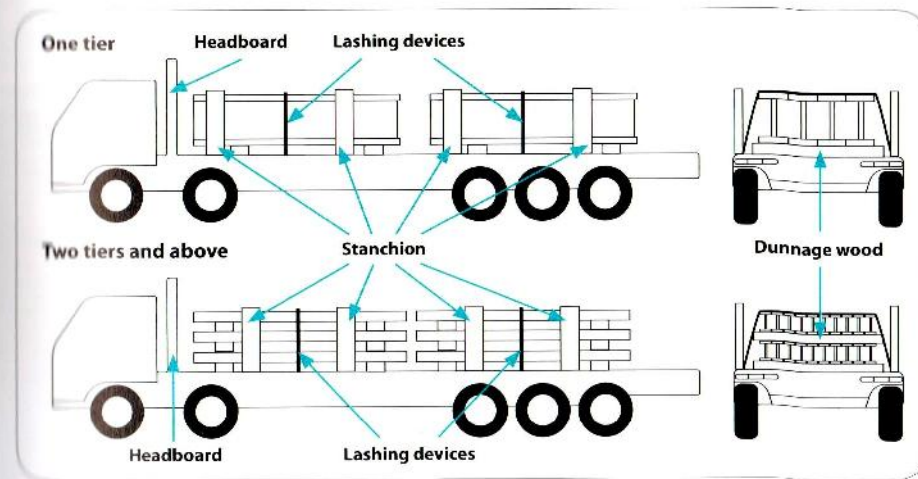

Figure 40: Loads in piles stacked one tier and above

- Regardless of the number of tiers, the loads must not be stack beyond the height of the stanchion and headboard.
- Adequate number of stanchion bars must be provided for each pile of load. For example, two stanchions can be installed on each side of a 20-footer trailer or at least four on each side of a 40-footer trailer.
- The height of the stanchion bars must be more than the height of the cargo.
- Adequate and proper lashing devices (at least one lashing device) must be used to secure the loads to prevent any movement.
- The loads must be stacked in a manner that is stable without lashing.
- There must be four to five pieces of dunnage wood in reasonably good condition at each layer. The cargo must be stable when placed on the dunnage woods.
- Four stanchion bars must be positioned vertically on both sides of the trailer to prevent the cargo from moving.



Figure 41: Sufficient stanchions/ steel bars must be fixed onto the platform and adequate lashing used on the steel pipes

- The front and rear piles must be lashed with a chain across the top layer to prevent the cargo from any movement (i.e., front lashing point between the first two stanchion bars, and rear lashing point between the last two stanchion bars).
- The vehicle should be affixed with headboard to give better protection to the driver.
- Friction mats can be placed between the cargo and the platform, and inbetween the piles. This will give greater friction to the load, preventing it from moving forward and hitting the cabin.
- A red cloth must be tied at the rear of any overhangs.

### 7.3.2 Pipes (bundled/ loose)

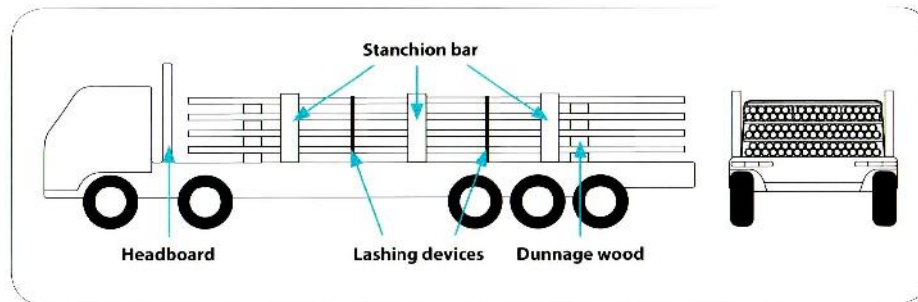

Figure 42: Loads stacked in two or more tiers

- The loads must not be stacked beyond the height of the stanchion and headboard.
- Adequate and proper lashing devices (at least two lashing devices per pile) must be used to secure the loads to prevent any movement.
- The loads must be stacked in a manner that is stable without lashing.
- Adequate number of stanchions must be used for each pile of load. For example, two stanchions can be installed on each side of a 20-footer trailer or at least four on each side of a 40-footer trailer.
- The height of the stanchion must be higher than the height of the cargo.
- The vehicle should be affixed with headboard to give better protection to the driver.
- Friction mats can be placed between the cargo and the platform, and inbetween the piles. This will give greater friction to the load, preventing it from moving forward and hitting the cabin.

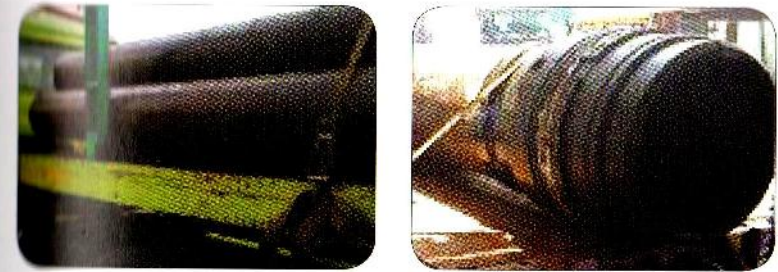

Figure 43: Trailers affixed with stanchions and lashing to secure pipes cargo

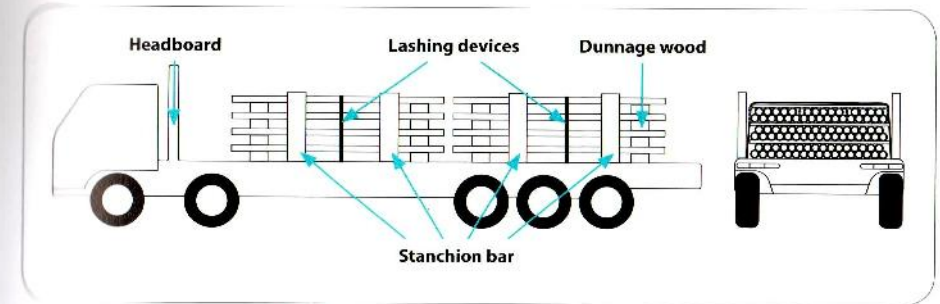

Figure 44: Loads, two tiers and above, stacked in two or more piles

- The loads must not be stacked beyond the height of the stanchion and headboard.
- Adequate and proper lashing devices (at least two lashing devices per pile) must be used to secure the loads to prevent any movement.
- The loads must be stacked in a manner that is stable without lashing.
- Adequate number of stanchions must be provided for each pile of load. For example, two stanchions can be installed on each side of a 20-footer trailer or at least four on each side of a 40-footer trailer.
- The height of the stanchion must be higher than the height of the cargo.
- The vehicle should be affixed with headboard to give better protection to the driver.
- Friction mats can be placed between the cargo and the platform, and inbetween the piles. This will give greater friction to the load, preventing it from moving forward and hitting the cabin.



### 7.3.3 Ingot/ Bars

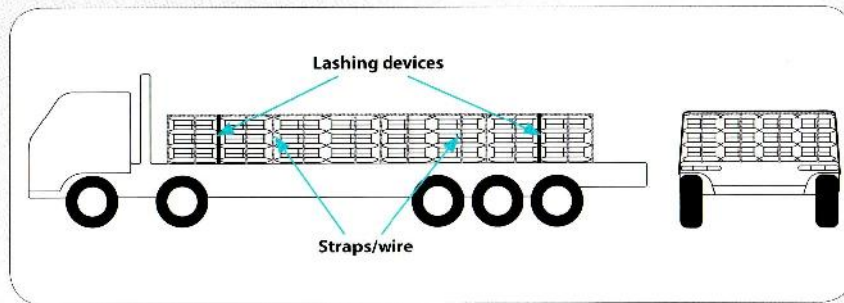
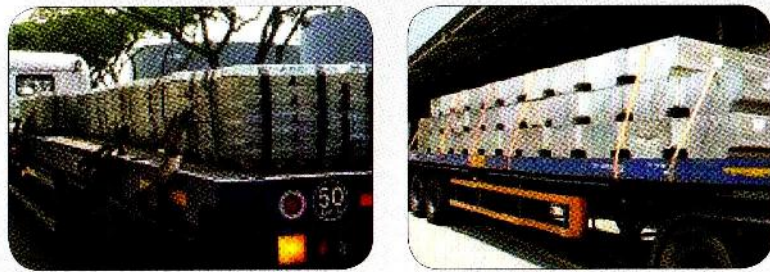

Figure 45: Stacking of ingots/ bars on trailer

- The straps/ wires should be checked for damage before loading.
- The loads must be stacked close to one other, and in a manner that is stable without lashing.
- If the spaces between the cargoes cannot be filled with other cargo or blocking, tiedowns can be wrapped around each cargo to secure it and prevent movement.
- The load should be placed at a distance away from the driver's cabin.
- Adequate and proper lashing devices must be used to secure the load to prevent any movement.
- The front and rear piles of load must be lashed.
- The vehicle should be affixed with headboard to give better protection to the driver.
- Friction mats can be placed between the cargo and the platform, and inbetween the piles. This will give greater friction to the load, preventing it from moving forward and hitting the cabin.

### 7.3.4 Coils

#### 7.3.4.1 Metal Sheet Coil (on trailers)

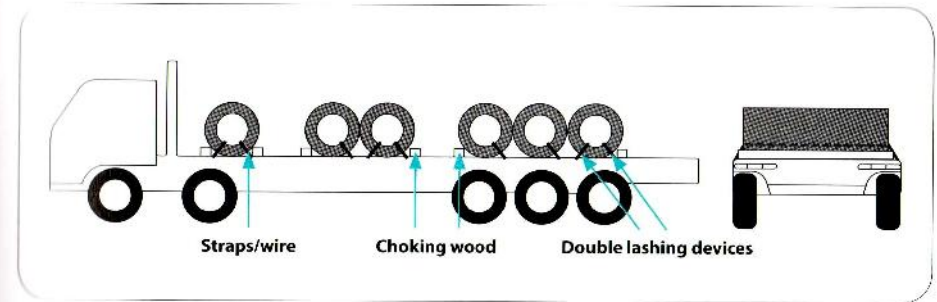

Figure 46: Metal sheet coils placed across the platform of the vehicle

- All the coils must be lashed. The first and last row of coils must be double lashed, with a chain pulled to the rear and another to the front to prevent movement.
- Each row of coils in the centre must be lashed with a chain and bind down vertically to prevent any movement.
- Coils behind the first row must be kept as vertically as possible (in straight line) and in contact with one other to prevent loose movement.
- The first and last row must be chocked across the vehicle. All coils must be chocked with dunnage wood to prevent any loose movement.
- The dimensions of the chocking wood used must be at least 100mm x 100mm (height x width).
- The arrangement of the rows on the vehicle is such that no row should be wider than the one in front of it.
- The vehicle should be affixed with headboard to give better protection to the driver.

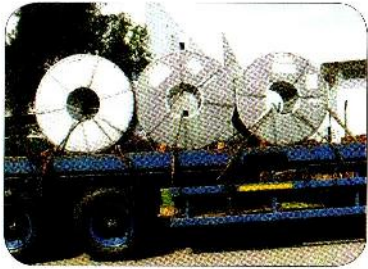

Figure 47: Each coil is secured and lashed



Figure 48: Coils must be placed in one straight line

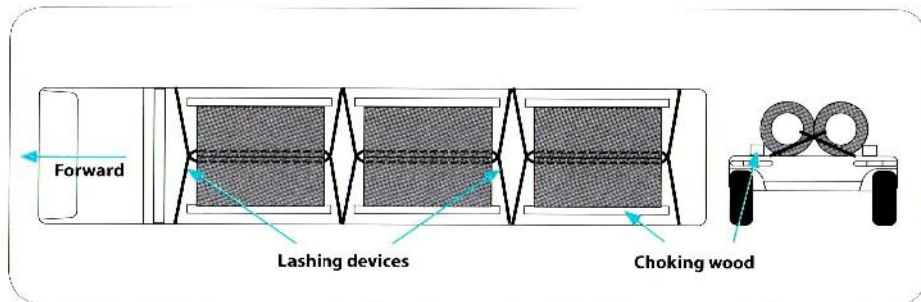

Figure 49: Metal sheet coils placed along the platform of the vehicle

- The rows must be lashed and chocked along the vehicle.
- The dimensions of the choking wood used must be at least 100mm x 100mm (height x width).

### 7.3.4.2 Metal Sheet Coil (palletised)

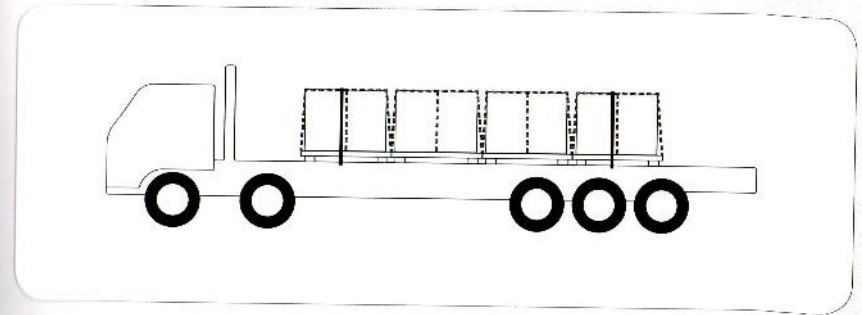

Figure 50: Coils on pallet

#### For metal sheet coils strapped on pallet placed along the platform of the vehicle;

- The first and last rows must be lashed.
- Each row of pallet must be in contact with the one in front of it.
- The coil should be secured to the pallet to withstand any force that may act on it.
- A friction mat can be placed under the pallet to increase the friction between the pallet and the deck, hence preventing movement.

### 7.3.4.3 Metal Coil (on wedge bed)

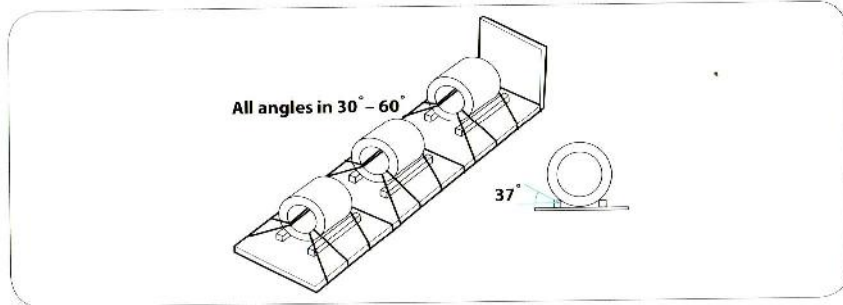

Figure 51: Coils secured on special brackets

- Loop lashing or edge protection can be used to prevent movement.
- This method of loading is applicable for special requirement by customers.

### 7.3.4.4 Steel Wire Coil



Figure 52: Vertical steel bar placed to prevent forward and rearward movement

- Every row of the steel wire coil is chocked and loaded across the trailer.
- The front and last rows must be double lashed to prevent forward and backward movement.
- The coils behind the first row must be kept as vertical as possible (in straight line) and in contact with one other.
- The rows of coils must be placed in contact with one other to prevent movement.
- Dunnage wood must be placed at the front for the first three rows and at the rear for the last three rows.
- Four stanchion bars should be positioned at the front and rear of the trailer to prevent forward and backward movement. The height of the stanchion must be at least half the height of the coils.

### 7.3.4.5 Cable Drum

- The cable drums behind the first row must be kept as vertical as possible and close to one other to prevent loose movement.
- All drums must be chocked with two pieces of dunnage wood to prevent forward and backward movement.
- All drums must also be lashed with a steel chain and binded down vertically to prevent loose movement.



Figure 53: Cable drums must be secured by proper chocking and lashing

## 7.4 Timber Load

- The straps/ wires should be checked for damage before loading.
- The load should be kept to a uniform height. Where possible, the uneven end should be at the rear of the vehicle and tied together to prevent whipping.
- Light timber load can be carried on vehicles with sideboards where the height of the load does not exceed the height of the sideboards. If the height of the load exceeds the height of the sideboards, the load must be lashed.
- Any loose ends of timber at the rear of the vehicle should be secured and pulled downward to minimise whipping.
- Vehicles with open platforms should be affixed with headboards.

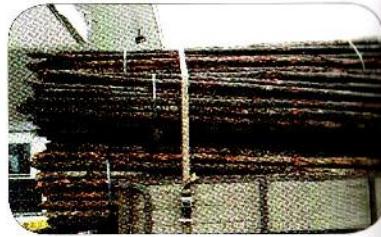

Figure 54: Light load—loose timber transported on vehicles

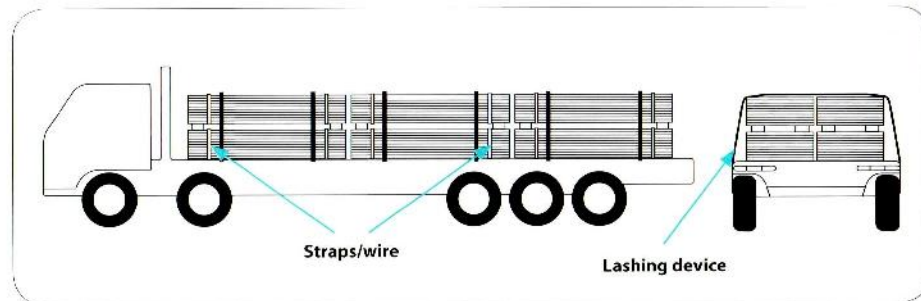

Figure 55: Transportation of timber load on open platform

### Timber Cargoes (Side Protruding Outward)

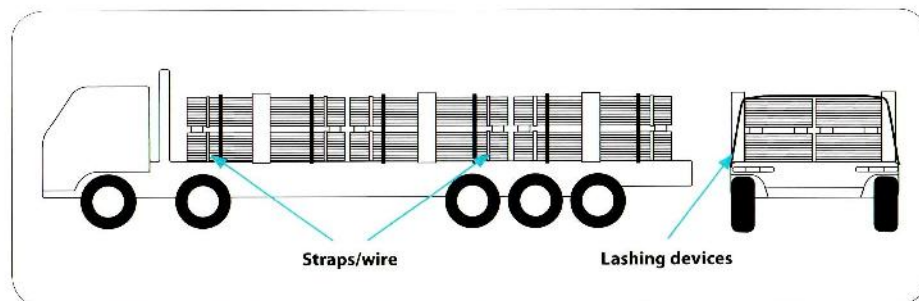

Figure 56: Timber load with side protruding outward

- The vehicle must be fitted with side stanchions to prevent the loads from toppling when the loads' sides are protruding outwards.
- The load should be secured such that no part of it is free to move in any direction independently from the rest.
- The height of the stanchions used must be appropriate for the height of the load and they should be properly secured.

### Timber Cargoes

- The load must not be stacked above the height of the vehicle's cabin.
- The load should be secured in a manner that no part of it is free to move in any direction independently from the rest.
- Each row of the load must be properly lashed.

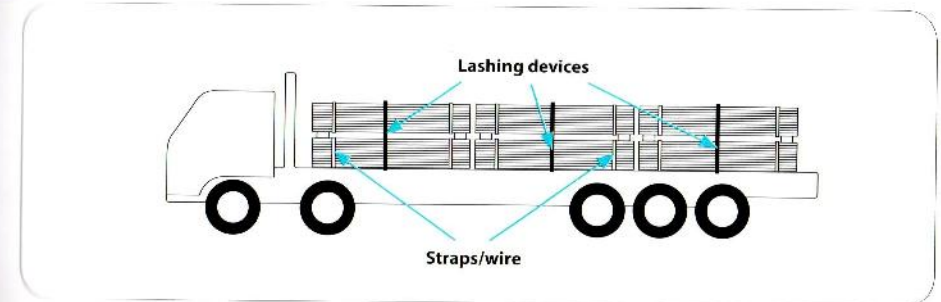

Figure 57: Timber load on open platform

## 7.5 Heavy Machines / Equipment



Figure 58: Usage of proper equipment and device to secure heavy and bulky cargo on low bed trailer



Figure 59: Proper chocking and lashing device applied to secure cargo from any movement

- Low bed trailers are used for the transportation of OOG containers and oversized/ heavy cargo such as machinery, excavator, crawler crane, construction equipment and other heavy lifts.
- These trailers are also used for loads with weight and height restrictions on public roads.
- Some low bed trailers allow machines or equipment to be driven onto their platforms.

## 7.6 Containers



1. Twistlocks

Figure 60: Position of twistlocks on trailer

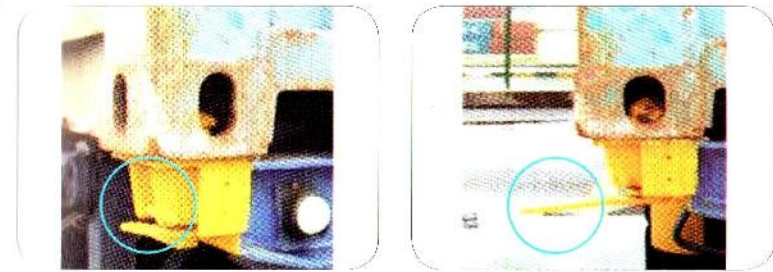

Twistlock in locked position.

Twistlock in unlocked position.

Figure 61: Use of twistlocks to secure the container to be safely loaded onto trailer

### Container Trucking

- Trailers are used to transport various types of containers which include general purpose, reefer, tank, open top, door open, flat rack, etc.
- Twistlocks are provided on the trailers for locking the containers.
- These twistlocks must be locked immediately when the containers are mounted onto the trailers.

## 7.7 Precast



Figure 62: Trailers mounted with steel frames

- Sling belts and stoppers should be provided on the trailer to secure precast components delivered in horizontal position.
- For precast components delivered in vertical position, galvansied wires and chain block should be used. Chain or sling belt can be used to further secure the load.
- Overloading of precast components on the trailer must be avoided at all times.
- The height between the ground and the highest point on the trailer should be checked against applicable traffic regulations to ensure compliance.
- Load balancing of precast components at the two sides of the trailer (with steel frames) should be checked before leaving the precast factory.
- It is recommended to affix headboard to give better protection to the driver.

## 7.8 Others

### 7.8.1 Jumbo Bags



Figure 63: Jumbo bags on lorry, minimum lashing to first and last row is required

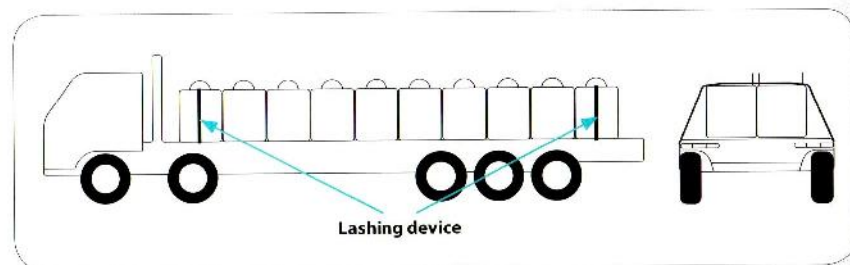

Figure 64: Jumbo bags on trailer, first and last row of the cargo must be lashed

Jumbo bags must be loaded onto the vehicle in the following manner: each bag must be in contact with the one in front of it, and there can only be one layer of bags.

- The first row of cargo should be placed as close as possible to the headboard.
- The first and last rows must be properly lashed.
- It is recommended that every row of cargo is lashed from the top to both sides to prevent movement and the cargoes from slipping off the vehicle.

### 7.8.2 Scrap Metal

- The vehicle should not be overloaded, so that the cargo would not slipped off during transportation.
- It is recommended that light weight cargo is covered with a net or canvas during transportation to prevent the cargo from being blown off.



Figure 65: The height of cargo load should not exceed that of the bin

### 7.8.3 Car Transporters



Figure 66: Ensure that proper equipment and securing devices are used for transporting cars/lorries on deck of trailers



Front Restraining Point On Vehicle



Rear Restraining Point On Vehicle



Front Restraining Point On Platform



Rear Restraining Point On Platform

Figure 67: Provide proper and secure webbing system for tyres

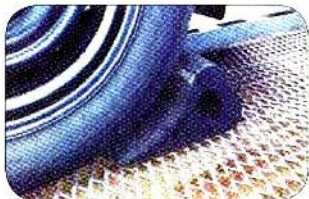

Front Wheel Chock



Rear Wheel Chock

Figure 68: Provide proper chock system at the front and back of every wheel

- Car transporters are specially designed trailers which are used to carry motor vehicles such as cars, vans, pick-up trucks and land rovers.
- A ramp is normally provided at the back of the trailer to allow the vehicles to be moved up and down the trailer.
- The vehicles must be secured to the platform in accordance to the requirement(s) of the manufacturer or transport company.
- It is recommended that proper chocks are provided at the front and back of every wheel of the vehicles to be transported.
- Proper restraints should be applied to prevent accidental movement of the wheels of the transported vehicles.

### 7.8.4 Tote Bins

- The first row of tote bins must be placed as close as possible to the headboard.
- The tote bins behind the first row should be placed close to one another to minimise movement.
- Every row of tote bins must be lashed with a lashing belt to prevent any movement.



Figure 69: Tote bins on lorry, minimum front and last row must be lashed, to prevent any movement.

### 7.8.5 Metal Panels

- The first row of cargos is placed as close as possible to the headboard to prevent forward movement.
- The side boards must be closed and secured to prevent the cargoes from sideways movement.
- Each vertical row of cargo must be lashed with two lashing belts across the top layer from the front to the rear to prevent forward and backward movements.



Figure 70: Metal panels on lorry, first row of cargo is placed near the headboard; the front and back rows must be lashed

### 7.8.6 Other Cargo Types

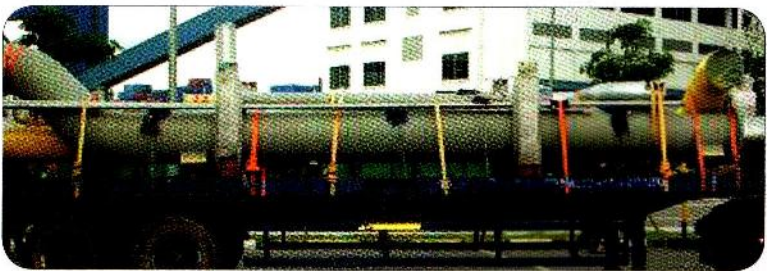
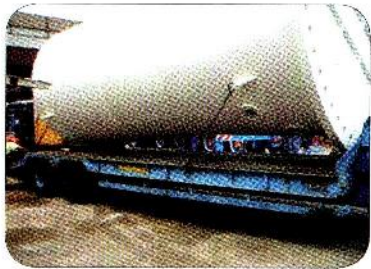

- All cargoes must be secured with proper and adequate lashing to anchor points on trailer side members.
- Proper blocking devices should be used to restrain the loads from shifting forward.
- Loose cargo should be properly chocked and secured to prevent any movement.
- Proper equipment must be used to transport different types of cargo of different height and weight.

Figure 71: Provide proper equipment for transporting cargoes of different sizes with proper and adequate lashing to anchor points



## 8. Dos and Don'ts for Loading on Vehicles

The Dos and Don'ts for safe loading on vehicles, the stacking and placement of cargoes, and the securing devices.

### Dos



Cargo must be loaded within the height of the container bin so objects would not spill out easily during movement.

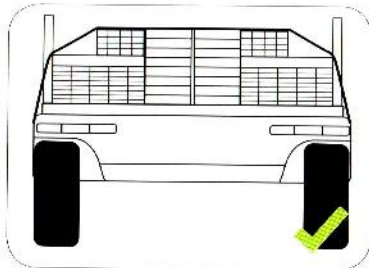

Correct load position—weight distributed evenly across the trailer, improving vehicle stability.

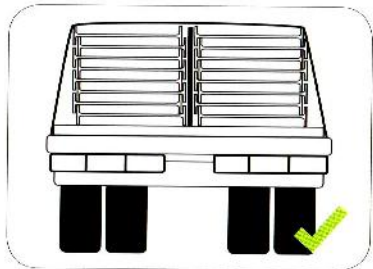

Double stacked load must be locked together with no gaps "over the top" chains.

### Don'ts



Vehicle should not be overloaded to prevent objects from spilling out during movement.

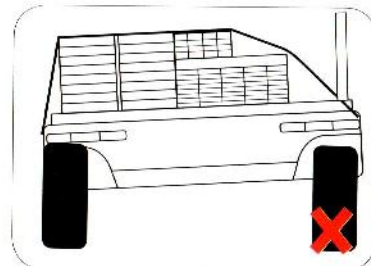

Incorrect load position—centre of load offsets to one side causing the vehicle to become unstable.

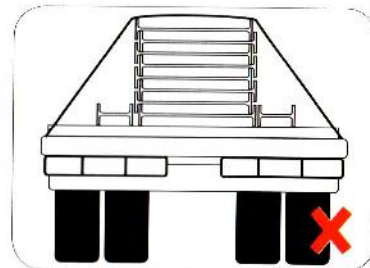

Outside columns not clamped by "over the top" chains. Entire load must be belly wrapped.

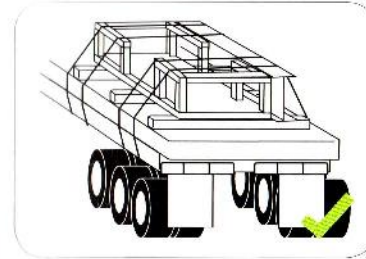

Use crates or steel boxes to contain and block items against the headboard of the vehicle cabin.

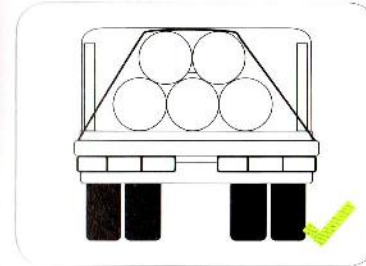

Load is secured and girders are used to prevent side movement.



More rows of the load lashed and secured to prevent any movement.



Cargoes are properly stacked.

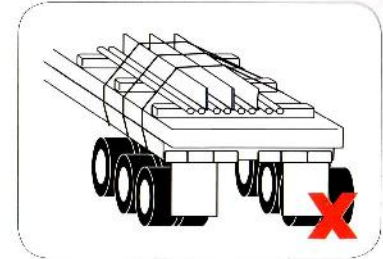

Difficult, slippery or individual products that are hard to restrain, should not be secured as loose items.

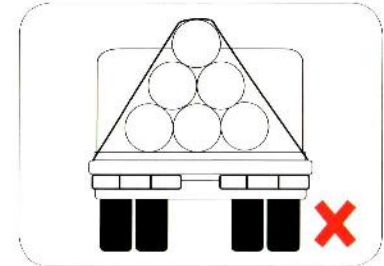

Load is higher than the headboard and there is no blocking. Girders are not used to prevent side movement.

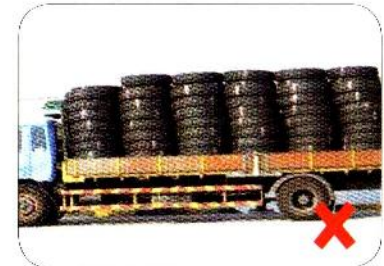

Load is over the height of the cabin. No proper lashing to secure the load from movement.

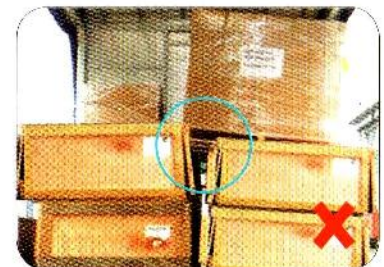

Cargoes are not properly stacked. Poor load distribution.



Only one layer of jumbo bag cargoes is allowed to be loaded on the vehicle.



There should not be more than one layer of jumbo bag cargoes.



It is a good practice to hang a red cloth for overlength cargo to alert users on the roads or at workplaces.



No proper indication for overlength cargo causes danger to users on the roads or at workplaces.



Ensure that the lorry's side boards are in good condition so that they can withhold the load of the cargoes.



Lorry's side board is damaged and giving way. Load is not properly secured.



A good lashing device will secure the cargo from any movement.



Defect lashing device should not be used as it will give way easily.



Proper vehicle for overheight and overwidth container.



Improper vehicle for overheight and overwidth container.



Bundles of steel rods must be properly stacked and lashed and kept within the height of the vertical girder.



Bundles of steel rods are not properly secured.

### More on Proper and Safe Loading



1. Twist locks are in locked position  
Overheight load is well contained in an open top container with twistlocks used to secure the container.



1. Padding  
2. Wire ropes and tensioners are used in the unit of the load

Each unit of the load is tied-down by wire rope. Padding is used on top edge of the load.



Loads are lashed and secured.



Cargoes are stacked closed to each load and secured with lashing.

### More on Unsafe Loading



Cargo load is above the stanchion height and is not secured by any lashing device.



Loose cargo is not secured by any lashing device.



Cargo over the height of the headboard.



Timber load is not properly stacked and there is no lashing.



The cargo is not properly secured to the girder of the lorry.



Improper stanchion used for pipe cargoes.



No lashing for bundled steel pipes and stanchion bar is deformed.



Damaged stanchion.



No lashing and headboard, improper stanchion bar used (cargo over stanchion bar).



No lashing and headboard, improper and damaged stanchion bar used (cargo over stanchion bar).



Height of cargo over the height of stanchion.



Load not distributed uniformly on the platform of trailer.

## 9. Acknowledgements

Ministry of Manpower – OSH Inspectorate	Ms Adeline Chang
Workplace Safety & Health Council (WSHC)	Mr Lim Meng Ann
	Mr Edd Hong Shuqi
Container Depot Association (Singapore) (CDAS) Lead Association	Mr A Sharafdeen
	Mr Lim Kian Chin
	Ms Laura Lim
	Mr Benjamin Lee
Singapore Logistics Association (SLA)	Mr Quek Keng Liang
	Mr Poh Key Boon
	Mr Daniel Wan
	Mr Sarbudeen Ajees
	Mr Loh Chia Wee
	Mr Ryan Oh Eng Wee
	Mr Kevi Sandhu
Singapore Transport Association (STA)	Mr Jimmy Ng
	Mr Thomas Chang Kong Meng
	Mr Dave Ng
Jurong Port Pte Ltd (JP)	Mr Eugene Seah
	Mr Adrian Ng Kok Wee
	Mr Robert Chan
	Mr Ivan Tan
PSA Corporation Ltd (PSA)	Mr S. Gunasagaran
	Mr Fong Kum Hor

© Photographs courtesy of Bok Seng Logistics, Container Depot Association (Singapore), CWT Limited, Jurong Port Pte Ltd, Poh Tiong Choon Logistics Ltd, PSA Corporation Ltd, Thong Lee Container Service Pte Ltd, Toll Logistics (Asia) Limited, Trans Auto Logistics Pte Ltd, UBTS Pte Ltd, Yang Kee Logistics Pte Ltd and all the contributing organisations.

Published in May 2010 by the Workplace Safety and Health Council in collaboration with the Ministry of Manpower.

All rights reserved. This publication may not be reproduced or transmitted in any form or by any means, in whole or in part, without prior written permission. The information provided in this publication is accurate as at time of printing. All cases shared in this publication are meant for learning purposes only. The learning points for each case are not exhaustive and should not be taken to encapsulate all the responsibilities and obligations of the user of this publication under the law. The Workplace Safety and Health Council does not accept any liability or responsibility to any party for losses or damage arising from following this publication.

This publication is available on the Workplace Safety and Health Council website: [www.wshc.gov.sg](http://www.wshc.gov.sg)  
Email: [contact@wshc.gov.sg](mailto:contact@wshc.gov.sg)

# Workplace Safety and Health Guidelines

## Safe Loading on Vehicles

